



Service Bulletin SB0073

Date: December 2004
From: Capstone Technical Support
Subject: Wiring Interlock between Multiple C30 MicroTurbines with
Common Exhaust Duct

Systems Affected

All Capstone Turbine Corporation[®] Model C30 systems operating with a common exhaust duct including systems with back flow dampers.

Safety Precautions

Only Capstone Authorized Serviced Providers (ASP's) should open the MicroTurbine and other equipment connected to the MicroTurbine. The systems can include multiple sources of power. The fuel used by the MicroTurbine is flammable and explosive. Keep flames, cigarettes, sparks, and electrical arc-producing equipment away from the MicroTurbine. Observe and adhere to the Safety Instructions contained within the MicroTurbine documentation.

Description of Problem

This service bulletin is intended to notify Authorized Service Providers of a possible safety issue/fire hazard or component failure relating to MicroTurbine systems sharing a common exhaust duct.

The back flow damper on two or more MicroTurbine systems sharing a common exhaust duct may warp after exposure to heat. This damper failure may affect the seal that prevents exhaust back flow and cause hot exhaust from an operating MicroTurbine unit to flow backwards through a non-operating MicroTurbine unit.

Reverse flow of hot exhaust may cause overheating of the generator and engine inlet components, resulting in damage to those components. In addition, damage to the non-operating MicroTurbine can result during a start of another unit due to backpressure on the engine's rotating components.

All MicroTurbines on a common duct must run simultaneously at the same power level. In addition, Capstone requires a wiring interlock mechanism to be installed between MicroTurbine systems.

Recommended Action

Capstone requires performing the recommended procedure as an interim solution while an on-going investigation and possible alternative solutions are being explored and tested.

Perform the following steps:

1. Command all MicroTurbines OFF.
2. Perform the following MicroTurbine-to-MicroTurbine series connections:

NOTE: Any output relay and fault input may be used. Output Relay 1 and Fault Input 1 are used in this example.

○ Two MicroTurbine configuration

Connect MicroTurbine #1 Output Relay 1 to MicroTurbine #2 Fault Input 1.
Connect MicroTurbine #2 Fault Input 1 to MicroTurbine #1 Output Relay 1.

Connections for Model C30:

Output Relay 1 – Connector TB5 - Pins 1 and 2

Fault Input 1 – Connector TB4 – Pins 5 and 6

○ Three or more MicroTurbine configuration

Connect the last MicroTurbine # $\langle n \rangle$ Output Relay 1 to MicroTurbine # 1 Fault Input 1.
Connect MicroTurbine # $\langle n \rangle$ Fault Input 1 to MicroTurbine # $\langle n-1 \rangle$ Output Relay 1.

Connections for C30:

Output Relay 1 – Connector TB5 - Pins 1 and 2

Fault Input 1 – Connector TB4 – Pins 5 and 6

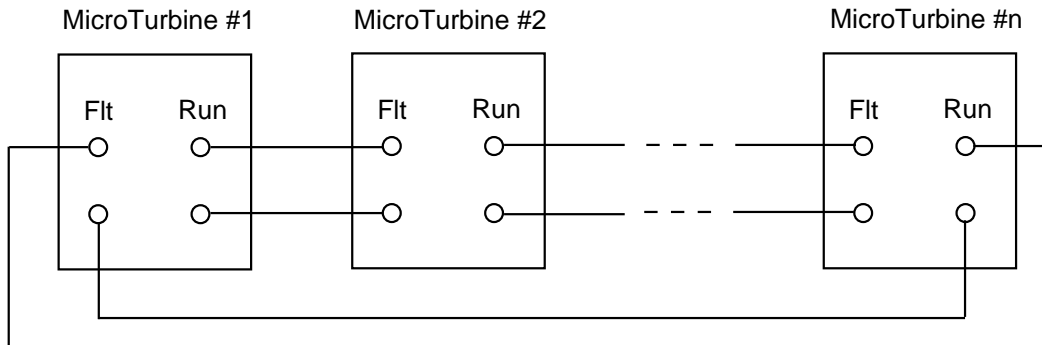

Figure 1. MicroTurbine - MicroTurbine Interconnections

3. Set the following software parameters on each MicroTurbine using the display panel:
 - a) On the UCB Relays menu for Output Relay 1, program the state to Run and function to Active Open.
 - b) On the System Settings menu, program the Fault Input 1 to Enable, SSL to 3, and Time to 12 seconds.

4. Set all MicroTurbine power demands to the same level (example: all systems commanded to 30kW).
 5. Turn OFF the Auto Restart.
 6. Command all MicroTurbines ON.
 7. Proceed with the normal operation of the MicroTurbines. If the fault code Compressor Inlet Thermistor High Temperature Warning (Fault Code 3008) is declared, it indicates that a backflow condition persists. Shut down all MicroTurbines, send a Field Service Report to Capstone, and contact Capstone Technical Support.
 8. To maintain maximum system availability while servicing a non-operating MicroTurbine interlocked with other MicroTurbines, proceed as follows:
 - a) Insert a piece of sheet metal to fully block the exhaust of the non-operating MicroTurbine. This will prevent back flow and potential damage to inlet components.
 - b) Disconnect the interlock mechanism from the non-operating MicroTurbine. Make sure ALL operating systems remain interlocked.
 - c) Start the remaining MicroTurbine systems.
 - d) Make repairs to non-operating MicroTurbine system.
 - e) Shut down ALL operating systems.
 - f) Re-connect the interlock mechanism to the repaired MicroTurbine.
 - g) Remove the sheet metal inserted to fully block exhaust of repaired MicroTurbine.
- CAUTION:** Gloves are recommended to remove the metal plate, which may be extremely hot after covering the exhaust duct.
- h) Re-start ALL interlocked MicroTurbines to resume full operation.

Responsibility

It is the responsibility of Capstone to provide work instructions contained within this document to the Authorized Service Providers.

It is the responsibility of the Authorized Service Providers to contact the customer to inform and schedule the upgrade.

It is the responsibility of the Authorized Service Providers to provide Capstone with a Field Service Report upon completion of the upgrade.

After January 1, 2005, Capstone shall not be held responsible for any failures that occur as a result of the MicroTurbine being installed without proper interlock protection.

Capstone Technical Support

If you have additional questions, please contact:

Capstone Technical Support

Toll Free Telephone: (877) 282-8966

Service Telephone: (818) 407-3600 • Fax: (818) 734-1080

E-mail: service@capstoneturbine.com

Capstone Applications Support

Toll Free Telephone: (877) 716-2929

Service Telephone: (818) 407-3692 • Fax: (818) 734-1092

E-mail: applications@capstoneturbine.com

Capstone Technical Support (Japan)

Service Telephone: (818) 407-3700 • Fax: (818) 734-1080

E-mail: servicejapan@capstoneturbine.com